

A decorative graphic on the left side of the page featuring a dashed circle, a solid blue circle, and several overlapping curved lines in blue and grey.

Product Manual

# Constellation® Serial ATA

**ST9500530NS**  
**ST9160511NS**

100538694  
Rev. C  
July 2010

## Revision history

Revision	Date	Sheets affected or comments
Rev. A	02/24/09	Initial release.
Rev. B	04/20/09	5, 7-9, 12-13 and 15.
Rev. C	07-20-10	Trademark revision.

© 2010 Seagate Technology LLC. All rights reserved.

Publication number: 100538694, Rev. C July 2010

Seagate, Seagate Technology and the Wave logo are registered trademarks of Seagate Technology LLC in the United States and/or other countries. Momentus and SeaTools are either trademarks or registered trademarks of Seagate Technology LLC or one of its affiliated companies in the United States and/or other countries. All other trademarks or registered trademarks are the property of their respective owners.

No part of this publication may be reproduced in any form without written permission of Seagate Technology LLC. Call 877-PUB-TEK1(877-782-8651) to request permission.

One gigabyte, or GB, equals one billion bytes and one terabyte, or TB, equals one trillion bytes. Your computer's operating system may use a different standard of measurement and report a lower capacity. In addition, some of the listed capacity is used for formatting and other functions, and thus will not be available for data storage. Seagate reserves the right to change, without notice, product offerings or specifications.

# Contents

<b>1.0</b>	<b>Introduction</b>	<b>1</b>
1.1	About the Serial ATA interface	2
<b>2.0</b>	<b>Drive specifications</b>	<b>3</b>
2.1	Specification summary tables	3
2.2	Formatted capacity	6
2.2.1	LBA mode	6
2.3	Default logical geometry	6
2.4	Recording and interface technology	6
2.5	Physical characteristics	7
2.6	Seek time	7
2.7	Start/stop times	7
2.8	Power specifications	8
2.8.1	Power consumption	8
2.8.2	Conducted noise	11
2.8.3	Voltage tolerance	11
2.8.4	Power-management modes	12
2.9	Environmental specifications	13
2.9.1	Ambient temperature	13
2.9.2	Temperature gradient	13
2.9.3	Humidity	13
2.9.4	Altitude	13
2.9.5	Shock	13
2.9.6	Vibration	14
2.10	Acoustics	15
2.11	Electromagnetic immunity	15
2.12	Reliability	16
2.12.1	Annualized Failure Rate (AFR) and Mean Time Between Failures (MTBF)	16
2.13	Agency certification	16
2.13.1	Safety certification	16
2.13.2	Electromagnetic compatibility	16
2.13.3	FCC verification	17
2.14	Environmental protection	18
2.14.1	European Union Restriction of Hazardous Substances (RoHS) Directive	18
2.14.2	China Restriction of Hazardous Substances (RoHS) Directive	18
2.15	Corrosive environment	18
<b>3.0</b>	<b>Configuring and mounting the drive</b>	<b>19</b>
3.1	Handling and static-discharge precautions	19
3.2	Configuring the drive	20
3.3	Serial ATA cables and connectors	20
3.4	Drive mounting	21
3.5	Cooling	22
<b>4.0</b>	<b>Serial ATA (SATA) interface</b>	<b>23</b>
4.1	Hot-Plug compatibility	23
4.2	Serial ATA device plug connector pin definitions	24
4.3	Supported ATA commands	25
4.3.1	Identify Device command	27
4.3.2	Set Features command	31
4.3.3	S.M.A.R.T. commands	32
<b>5.0</b>	<b>Seagate Technology support services</b>	<b>33</b>



## List of Figures

Figure 1.	Typical 5V/12V startup and operation current profile for ST9500530NS .....	10
Figure 2.	Typical 5V/12V startup and operation current profile for ST9160511NS .....	10
Figure 3.	Serial ATA connectors .....	20
Figure 4.	Attaching SATA cabling .....	20
Figure 5.	Mounting dimensions—top, side and end view .....	21
Figure 6.	Air flow .....	22



## 1.0 Introduction

---

This manual describes the functional, mechanical and interface specifications for the following Seagate Constellation® Serial ATA model drives:

ST9500530NS      ST9160511NS

These drives provide the following key features:

- 7200 RPM spindle speed.
- High instantaneous (burst) data-transfer rates (up to 300 Mbytes per second).
- Perpendicular recording technology provides the drives with increased areal density.
- State-of-the-art cache and on-the-fly error-correction algorithms.
- Native Command Queueing with command ordering to increase performance in demanding applications.
- Full-track multiple-sector transfer capability without local processor intervention.
- Quiet operation.
- SeaTools diagnostic software performs a drive self-test that eliminates unnecessary drive returns.
- Support for S.M.A.R.T. drive monitoring and reporting.
- Supports latching SATA cables and connectors.
- Worldwide Name (WWN) capability uniquely identifies the drive.

## 1.1 About the Serial ATA interface

The Serial ATA interface provides several advantages over the traditional (parallel) ATA interface. The primary advantages include:

- Easy installation and configuration with true plug-and-play connectivity. It is not necessary to set any jumpers or other configuration options.
- Thinner and more flexible cabling for improved enclosure airflow and ease of installation.
- Scalability to higher performance levels.

In addition, Serial ATA makes the transition from parallel ATA easy by providing legacy software support. Serial ATA was designed to allow you to install a Serial ATA host adapter and Serial ATA disc drive in your current system and expect all of your existing applications to work as normal.

The Serial ATA interface connects each disc drive in a point-to-point configuration with the Serial ATA host adapter. There is no master/slave relationship with Serial ATA devices like there is with parallel ATA. If two drives are attached on one Serial ATA host adapter, the host operating system views the two devices as if they were both “masters” on two separate ports. This essentially means both drives behave as if they are Device 0 (master) devices.

**Note.** The host adapter may, optionally, emulate a master/slave environment to host software where two devices on separate Serial ATA ports are represented to host software as a Device 0 (master) and Device 1 (slave) accessed at the same set of host bus addresses. A host adapter that emulates a master/slave environment manages two sets of shadow registers. This is not a typical Serial ATA environment.

The Serial ATA host adapter and drive share the function of emulating parallel ATA device behavior to provide backward compatibility with existing host systems and software. The Command and Control Block registers, PIO and DMA data transfers, resets, and interrupts are all emulated.

The Serial ATA host adapter contains a set of registers that shadow the contents of the traditional device registers, referred to as the Shadow Register Block. All Serial ATA devices behave like Device 0 devices. For additional information about how Serial ATA emulates parallel ATA, refer to the “Serial ATA: High Speed Serialized AT Attachment” specification. The specification can be downloaded from [www.serialata.org](http://www.serialata.org).

## 2.0 Drive specifications

---

Unless otherwise noted, all specifications are measured under ambient conditions, at 25°C, and nominal power. For convenience, the phrases *the drive* and *this drive* are used throughout this manual to indicate the following drive models:

ST9500530NS      ST9160511NS

Product data communicated in this manual is specific only to the model numbers listed in this manual. The data listed in this manual may not be predictive of future generation specifications or requirements. If you are designing a system which will use one of the models listed or future generation products and need further assistance, please contact your Field Applications Engineer (FAE) or our global support services group as shown in Section 5.0.

### 2.1 Specification summary tables

The specifications listed in the following tables are for quick reference. For details on specification measurement or definition, see the appropriate section of this manual.

**Table 1: Drive specifications summary for 500 and 160 GB models**

Drive specification	ST9500530NS	ST9160511NS
Formatted Gbytes (512 bytes/sector)*	500	160
Guaranteed sectors	976,773,168	312,581,808
Heads	6	2
Discs	3	1
Bytes per sector	512	
Default sectors per track	63	
Default read/write heads	16	
Default cylinders	16,383	
Recording density, KBPI (kbits/in max)	1410	
Track density, KTPI (ktracks/in avg.)	200	
Areal density, (Gbits/in <sup>2</sup> avg)	283	
Spindle speed (RPM)	7200	
Internal data transfer rate (Mbits/sec max)	<b>1136</b>	
Sustained data transfer rate OD (Mbytes/sec max)	95	
I/O data-transfer rate (Mbytes/sec max)	300	
ATA data-transfer modes supported	PIO modes 0–4 Multiword DMA modes 0–2 Ultra DMA modes 0–6	
Cache buffer	32 Mbytes	
Height (mm max)	14.8 mm (0.583 inches)	
Width (mm max)	70.0 mm (2.76 inches)	
Length (mm max)	100.5 mm (3.957 inches)	
Weight (max)	196 grams (0.43 lbs)	188 grams ( <b>0.41</b> lbs)
Average latency	4.16 msec	
Power-on to ready (sec max)	20 sec	
Standby to ready (sec max)	6 sec	4 sec
Track-to-track seek time (msec typical)	0.5 read; 0.7 write	
Average seek, read (msec typical)	8.0	
Average seek, write (msec typical)	8.4	
Startup current (typical) 12V (peak)	2.0 amps	
Voltage tolerance (including noise)	5V ± 5% 12V ± 5%	
Ambient temperature	5° to 55°C (operating) –40° to 70°C (nonoperating)	
Temperature gradient (°C per hour max)	20°C (operating) 20°C (nonoperating)	
Relative humidity	5% to 95% (operating) 5% to 95% (nonoperating)	
Relative humidity gradient	20% per hour max	
Wet bulb temperature (°C max)	37.7 (operating) 40.0 (nonoperating)	
Altitude, operating	–60.96 m to 3048 m (–200 ft. to 10,000+ ft.)	
Altitude, nonoperating (below mean sea level, max)	–60.96 m to 12,192 m (–200 ft. to 40,000+ ft.)	
Operational Shock (max at 2 msec)	70 Gs	
Non-Operational Shock (max at 2 msec)	400 Gs	

Drive specification	ST9500530NS	ST9160511NS
Vibration, operating	5–22 Hz: 0.25 Gs, Limited displacement 22–350 Hz: 0.50 Gs 350–500 Hz: 0.25 Gs	
Vibration, nonoperating	5–500 Hz: 3.0 Gs	
Drive acoustics, sound power (bels)		
Active	2.6 (typical)	2.5 (typical)
Idle**	2.3 (typical)	2.1 (typical)
Nonrecoverable read errors	1 sector per 10 <sup>15</sup> bits read	
Annualized Failure Rate (AFR)	0.73%	
Warranty	To determine the warranty for a specific drive, use a web browser to access the following web page: <a href="http://www.seagate.com/support/service/">www.seagate.com/support/service/</a> From this page, click on the “Verify Your Warranty” link. You will be asked to provide the drive serial number, model number (or part number) and country of purchase. The system will display the warranty information for your drive.	
Motor start-stop cycles (25°C, 50% rel. humidity)	50,000	
Supports Hotplug operation per Serial ATA Revision 2.5 specification	Yes	

\*One Gbyte equals one billion bytes when referring to hard drive capacity. Accessible capacity may vary depending on operating environment and formatting.

\*\*During periods of drive idle, some offline activity may occur according to the S.M.A.R.T. specification, which may increase acoustic and power to operational levels.

## 2.2 Formatted capacity

Model	Formatted capacity*	Guaranteed sectors	Bytes per sector
ST9500530NS	500 Gbytes	976,773,168	512
ST9160511NS	160 Gbytes	312,581,808	

\*One Gbyte equals one billion bytes when referring to hard drive capacity. Accessible capacity may vary depending on operating environment and formatting.

### 2.2.1 LBA mode

When addressing these drives in LBA mode, all blocks (sectors) are consecutively numbered from 0 to  $n-1$ , where  $n$  is the number of guaranteed sectors as defined above.

See Section 4.3.1, "Identify Device command" (words 60-61 and 100-103) for additional information about 48-bit addressing support of drives with capacities over 137 Gbytes.

## 2.3 Default logical geometry

Cylinders	Read/write heads	Sectors per track
16,383	16	63

### LBA mode

When addressing these drives in LBA mode, all blocks (sectors) are consecutively numbered from 0 to  $n-1$ , where  $n$  is the number of guaranteed sectors as defined above.

## 2.4 Recording and interface technology

	500GB	160GB
Interface	Serial ATA (SATA)	
Recording method	Perpendicular	
Recording density, KBPI (kbits/inch max)	1410	
Track density, KTPI (ktracks/inch avg)	200	
Areal density (Gbits/inch <sup>2</sup> avg)	283	
Spindle speed (RPM) ( $\pm 0.2\%$ )	7200	
Internal data transfer rate (Mbits/sec max)	1136	
Sustained data transfer rate (Mbytes/sec max)	95	
I/O data-transfer rate (Mbytes/sec max)	300 (Ultra DMA mode 5)	

## 2.5 Physical characteristics

Maximum height	14.8 mm (0.583 inches)
Maximum width	70.0 mm (2.76 inches)
Maximum length	100.5 mm (3.957 inches)
Max weight	
ST9500530NS	196 grams (0.43 lbs)
ST9160511NS	188 grams (0.41 lbs)
Cache buffer	32 Mbytes (32,768 kbytes)

## 2.6 Seek time

Seek measurements are taken with nominal power at 25°C ambient temperature. All times are measured using drive diagnostics. The specifications in the table below are defined as follows:

- Track-to-track seek time is an average of all possible single-track seeks in both directions.
- Average seek time is a true statistical random average of at least 5,000 measurements of seeks between random tracks, less overhead.

*Typical seek times (msec)	Read	Write
Track-to-track	0.5	0.7
Average	8.0	8.4
Full Stroke	17.4	17.9
Average latency:	4.16	

\*Measured in performance mode.

**Note.** These drives are designed to consistently meet the seek times represented in this manual. Physical seeks, regardless of mode (such as track-to-track and average), are expected to meet the noted values. However, due to the manner in which these drives are formatted, benchmark tests that include command overhead or measure logical seeks may produce results that vary from these specifications.

## 2.7 Start/stop times

	ST9500530NS	ST9160511NS
Power-on to Ready (sec)	20 (max)	
Standby to Ready (sec)	6 (max)	4 (max)
Ready to spindle stop (sec)	20 (max)	

## 2.8 Power specifications

The drive receives DC power (+5V or +12V) through a native SATA power connector. See Figure 4 on page 20.

### 2.8.1 Power consumption

Power requirements for the drives are listed in the table on page 9. Typical power measurements are based on an average of drives tested, under nominal conditions, using 5.0V and 12.0V input voltage at 25°C ambient temperature.

- **Spinup power**

Spinup power is measured from the time of power-on to the time that the drive spindle reaches operating speed.

- **Standby mode**

During Standby mode, the drive accepts commands, but the drive is not spinning, and the servo and read/write electronics are in power-down mode.

**Table 2: DC power requirements**

Parameter	ST9500530NS (1.5GB)			ST9500530NS (3.0GB)		
	+5 V +/-5%	+12 V +/-5%	Power (watts)	+5 V +/-5%	+12 V +/-5%	Power (watts)
Average Idle Current	0.28	0.11	2.69	0.29	0.11	2.71
Advanced Idle Current						
Idle_A	0.24	0.10	2.42	0.24	0.10	2.45
Idle_B	0.14	0.08	1.71	0.15	0.08	1.72
Idle_C	0.14	0.05	1.37	0.15	0.05	1.38
Standby	0.16	0.02	1.05	0.17	0.02	1.06
Average Sleep Current	0.16	0.02	1.06	0.16	0.02	1.03
Maximum Start Current:						
DC (Peak DC)	0.39	0.64	9.64	0.40	0.65	9.77
AC (Peak AC)	0.73	1.50	21.59	0.72	1.55	22.25
Delayed Motor Start (DC max)	0.16	0.03	1.12	0.17	0.02	1.08
Peak Operating Current (random read):						
Typical DC	0.29	0.13	3.05	0.30	0.14	3.11
Maximum DC	0.29	0.15	3.22	0.30	0.15	3.30
Maximum DC (peak)	0.84	0.52	10.44	0.84	0.56	10.92
Peak Operating Current (random write):						
Typical DC	0.34	0.14	3.42	0.35	0.14	3.49
Maximum DC	0.36	0.14	3.50	0.36	0.15	3.59
Maximum DC (peak)	1.02	0.58	12.06	1.02	0.60	12.30
Peak operating current (sequential read):						
Typical DC	0.58	0.12	4.27	0.58	0.12	4.33
Maximum DC	0.59	0.12	4.35	0.60	0.12	4.44
Maximum DC (peak)	0.82	0.22	6.74	0.84	0.22	6.84
Peak operating current (sequential write):						
Typical DC	0.63	0.12	4.52	0.64	0.12	4.59
Maximum DC	0.67	0.12	4.77	0.68	0.12	4.84
Maximum DC (peak)	1.04	0.20	7.60	1.06	0.20	7.70

\*During periods of drive idle, some offline activity may occur according to the S.M.A.R.T. specification, which may increase acoustic and power to operational levels.

Parameter	ST9160511NS (1.5GB)			ST9160511NS (3.0GB)		
	+5 V	+12 V	Power	+5 V	+12 V	Power
<b>Voltage Regulation</b>	<b>+/-5%</b>	<b>+/-5%</b>	<b>(watts)</b>	<b>+/-5%</b>	<b>+/-5%</b>	<b>(watts)</b>
Average Idle Current	0.23	0.08	2.11	0.24	0.08	2.14
Advanced Idle Current						
Idle_A	0.23	0.08	2.08	0.24	0.08	2.10
Idle_B	0.14	0.06	1.46	0.15	0.06	1.49
Idle_C	0.14	0.04	1.25	0.15	0.04	1.27
Standby	0.16	0.02	1.02	0.17	0.02	1.04
Average Sleep Current	0.16	0.02	0.97	0.16	0.02	1.00
Maximum Start Current:						
DC (Peak DC)	0.41	0.62	9.47	0.41	0.62	9.51
AC (Peak AC)	0.57	0.77	12.11	0.57	1.09	15.94
Delayed Motor Start (DC max)	0.16	0.02	1.01	0.17	0.02	1.04
Peak Operating Current (random read):						
Typical DC	0.31	0.11	2.88	0.31	0.11	2.92
Maximum DC	0.31	0.12	3.01	0.32	0.12	3.07
Maximum DC (peak)	0.82	0.52	10.34	0.84	0.52	10.44
Peak Operating Current (random write):						
Typical DC	0.35	0.12	3.18	0.36	0.12	3.22
Maximum DC	0.35	0.12	3.23	0.36	0.12	3.28
Maximum DC (peak)	1.02	0.56	11.82	1.00	0.52	11.24
Peak operating current (sequential read):						
Typical DC	0.58	0.09	3.98	0.59	0.09	4.00
Maximum DC	0.60	0.09	4.08	0.60	0.09	4.11
Maximum DC (peak)	0.84	0.20	6.60	0.86	0.20	6.70
Peak operating current (sequential write):						
Typical DC	0.62	0.09	4.15	0.62	0.09	4.18
Maximum DC	0.67	0.09	4.46	0.68	0.09	4.49
Maximum DC (peak)	1.02	0.20	7.50	1.04	0.20	7.60

\*During periods of drive idle, some offline activity may occur according to the S.M.A.R.T. specification, which may increase acoustic and power to operational levels.

### 2.8.1.1 Typical current profiles

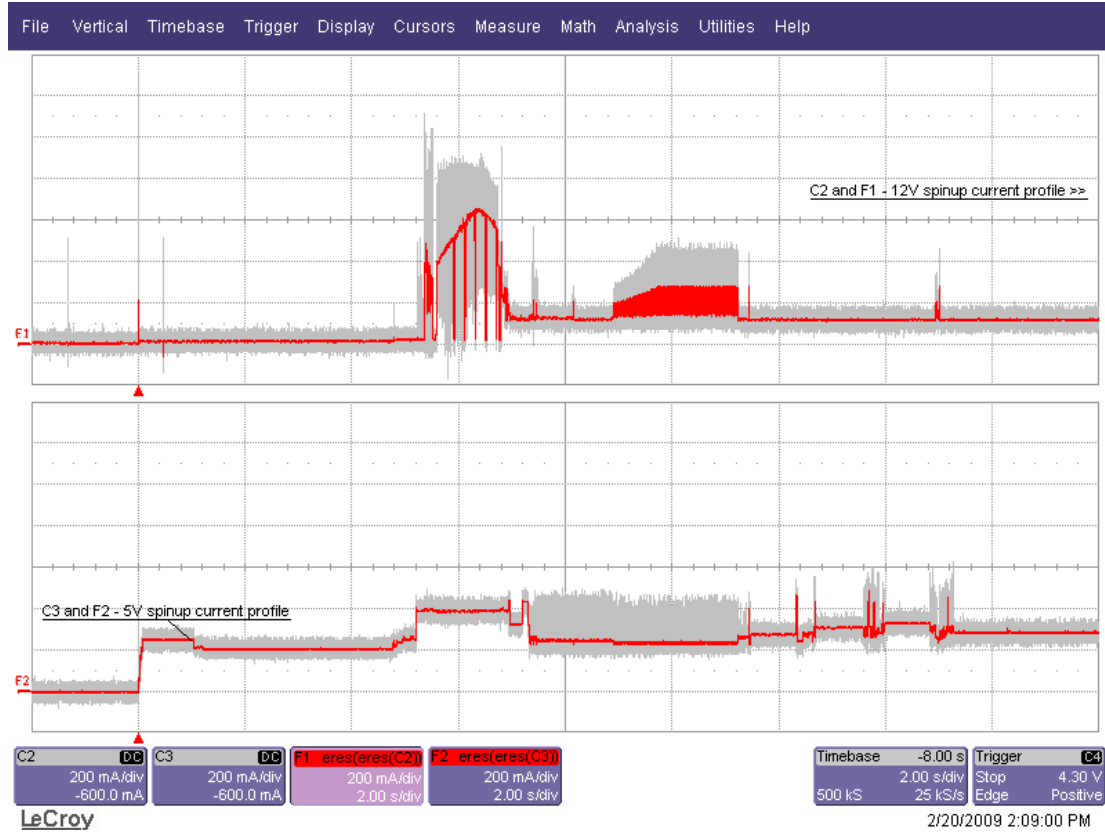

Figure 1. Typical 5V/12V startup and operation current profile for ST9500530NS

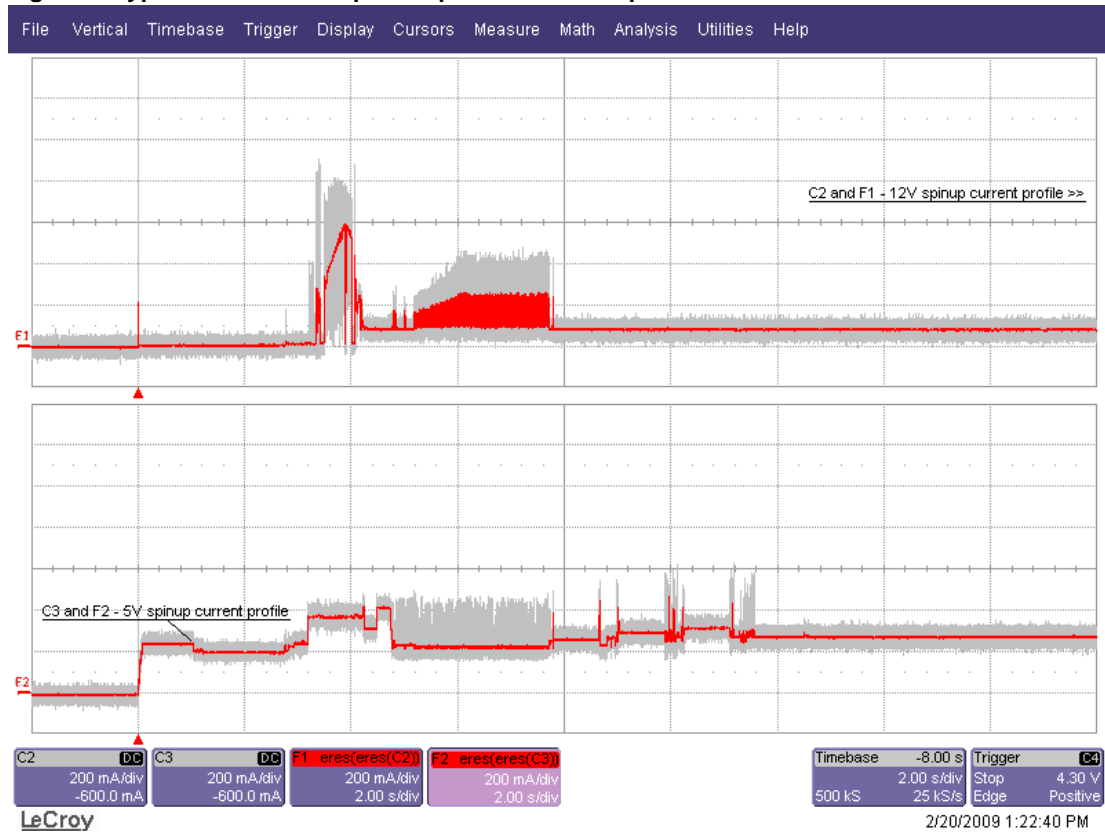

Figure 2. Typical 5V/12V startup and operation current profile for ST9160511NS

### 2.8.2 Conducted noise

Input noise ripple is measured at the host system power supply across an equivalent 80-ohm resistive load on the +12 volt line or an equivalent 15-ohm resistive load on the +5 volt line.

- Using 12-volt power, the drive is expected to operate with a maximum of 120 mV peak-to-peak square-wave injected noise at up to 10 MHz.
- Using 5-volt power, the drive is expected to operate with a maximum of 100 mV peak-to-peak square-wave injected noise at up to 10 MHz.

**Note.** Equivalent resistance is calculated by dividing the nominal voltage by the typical RMS read/write current.

### 2.8.3 Voltage tolerance

Voltage tolerance (including noise):

5V  $\pm 5\%$

12V  $\pm 5\%$

## 2.8.4 Power-management modes

### PowerChoice™ power management

Drives using the load/unload architecture provide programmable power management to tailor systems for performance and greater energy efficiency.

The table below lists the supported PowerChoice modes. The further you go down in the table, the more power savings you get. For example, Idle\_B mode results in greater power savings than Idle\_A mode. Standby mode results in the greatest power savings.

Mode	Description
Idle_A	Reduced electronics
Idle_B	Heads unloaded. Disks spinning at full RPM
Idle_C	Heads unloaded. Disks spinning at reduced RPM
Standby	Heads unloaded. Motor stopped (disks not spinning)

PowerChoice can be invoked using one of these two methods:

- Extended Power Conditions (EPC) Set Features Command method-Enable and initialize the idle condition timers.
- Standby Immediate and Idle Immediate command method-Use the EPC Set Features Command. This allows the host to directly transition the drive to any supported PowerChoice mode. The drive preserves the existing idle power settings.

### PowerChoice reporting methods

PowerChoice™ provides these reporting methods for tracking purposes:

#### Check Power Mode Reports

- Current power condition

#### Power Condition Log Reports

- Idle condition enabled/disabled
- If timer is changeable
- Typical recovery time from extended power conditions
- Current timer setting and Manufacturer default timer settings

#### SMART Read Data Attribute - Load/ Unload Cycle Counter

## 2.9 Environmental specifications

### 2.9.1 Ambient temperature

Ambient temperature is defined as the temperature of the environment immediately surrounding the drive. Actual drive case temperature should not exceed 60°C (140°F) within the operating ambient conditions.

Above 1,000 feet (305 meters), the maximum temperature is derated linearly to 112°F (44°C) at 10,000 feet (3,048 meters).

Operating:	5° to 55°C (41° to 131°F)
Nonoperating:	–40° to 70°C (–40° to 158°F)

### 2.9.2 Temperature gradient

Operating:	20°C per hour (68°F per hour max), without condensation
Nonoperating:	20°C per hour (86°F per hour max)

### 2.9.3 Humidity

#### 2.9.3.1 Relative humidity

Operating:	5% to 95% noncondensing (20% per hour max)
Nonoperating:	5% to 95% noncondensing (20% per hour max)

#### 2.9.3.2 Wet bulb temperature

Operating:	37.7°C (99.9°F max)
Nonoperating:	40.0°C (104.0°F max)

### 2.9.4 Altitude

Operating:	–60.96 m to 3,048 m (–200 ft. to 10,000+ ft.)
Nonoperating:	–60.96 m to 12,192 m (–200 ft. to 40,000+ ft.)

### 2.9.5 Shock

All shock specifications assume that the drive is mounted securely with the input shock applied at the drive mounting screws. Shock may be applied in the X, Y or Z axis.

#### 2.9.5.1 Operating shock

These drives comply with the performance levels specified in this document when subjected to a maximum operating shock of 70 Gs based on half-sine shock pulses of 2 msec. Shocks should not be repeated more than once every 2 seconds.

#### 2.9.5.2 Nonoperating shock

The nonoperating shock level that the drive can experience without incurring physical damage or degradation in performance when subsequently put into operation is 400 Gs based on a nonrepetitive half-sine shock pulse of 2 msec duration.

## 2.9.6 Vibration

All vibration specifications assume that the drive is mounted securely with the input vibration applied at the drive mounting screws. Vibration may be applied in the X, Y or Z axis.

### 2.9.6.1 Operating vibration

The maximum vibration levels that the drive may experience while meeting the performance standards specified in this document are specified below.

5–22 Hz	0.25 Gs (Limited displacement)
22–350 Hz	0.50 Gs
350–500 Hz	0.25 Gs

### 2.9.6.2 Nonoperating vibration

The maximum nonoperating vibration levels that the drive may experience without incurring physical damage or degradation in performance when subsequently put into operation are specified below.

5–500 Hz	3.0 Gs
----------	--------

## 2.10 Acoustics

Drive acoustics are measured as overall A-weighted acoustic sound power levels (no pure tones). All measurements are consistent with ISO document 7779. Sound power measurements are taken under essentially free-field conditions over a reflecting plane. For all tests, the drive is oriented with the cover facing upward.

**Note.** For seek mode tests, the drive is placed in seek mode only. The number of seeks per second is defined by the following equation:

$$(\text{Number of seeks per second} = 0.4 / (\text{average latency} + \text{average access time}))$$

**Table 3: Fluid Dynamic Bearing (FDB) motor acoustics**

	Active	Idle*
ST9500530NS	2.6 bels (typ)	2.3 bels (typ)
ST9160511NS	2.5 bels (typ)	2.1 bels (typ)

\*During periods of drive idle, some offline activity may occur according to the S.M.A.R.T. specification, which may increase acoustic and power to operational levels.

## 2.11 Electromagnetic immunity

When properly installed in a representative host system, the drive operates without errors or degradation in performance when subjected to the radio frequency (RF) environments defined in the following table:

**Table 4: Radio frequency environments**

Test	Description	Performance level	Reference standard
Electrostatic discharge	Contact, HCP, VCP: $\pm 4$ kV; Air: $\pm 8$ kV	B	EN 61000-4-2: 95
Radiated RF immunity	80 to 1,000 MHz, 3 V/m, 80% AM with 1 kHz sine 900 MHz, 3 V/m, 50% pulse modulation @ 200 Hz	A	EN 61000-4-3: 96 ENV 50204: 95
Electrical fast transient	$\pm 1$ kV on AC mains, $\pm 0.5$ kV on external I/O	B	EN 61000-4-4: 95
Surge immunity	$\pm 1$ kV differential, $\pm 2$ kV common, AC mains	B	EN 61000-4-5: 95
Conducted RF immunity	150 kHz to 80 MHz, 3 Vrms, 80% AM with 1 kHz sine	A	EN 61000-4-6: 97
Voltage dips, interrupts	0% open, 5 seconds 0% short, 5 seconds 40%, 0.10 seconds 70%, 0.01 seconds	C C C B	EN 61000-4-11: 94

## 2.12 Reliability

### 2.12.1 Annualized Failure Rate (AFR) and Mean Time Between Failures (MTBF)

The product shall achieve an Annualized Failure Rate - AFR - of 0.73% (Mean Time Between Failures - MTBF - of 1.2 Million hrs) when operated in an environment that ensures the HDA case temperatures do not exceed 40°C. Operation at case temperatures outside the specifications in Section 2.9 may increase the product Annualized Failure Rate (decrease MTBF). AFR and MTBF are population statistics that are not relevant to individual units.

AFR and MTBF specifications are based on the following assumptions for business critical storage system environments:

- 8,760 power-on-hours per year.
- 250 average motor start/stop cycles per year.
- Operations at nominal voltages.
- Systems will provide adequate cooling to ensure the case temperatures do not exceed 40°C. Temperatures outside the specifications in Section 2.9 will increase the product AFR and decrease MTBF.

Nonrecoverable read errors	1 per 10 <sup>15</sup> bits read, max
Annualized Failure Rate (AFR)	0.73% (nominal power, 40°C case temperature)
Motor start-stop cycles	50,000 cycles (at nominal voltage and temperature, with 60 cycles per hour and a 50% duty cycle)
Warranty	To determine the warranty for a specific drive, use a web browser to access the following web page: <a href="http://www.seagate.com/support/service/">www.seagate.com/support/service/</a> From this page, click on the "Verify Your Warranty" link. You will be asked to provide the drive serial number, model number (or part number) and country of purchase. The system will display the warranty information for your drive.
Preventive maintenance	None required.

## 2.13 Agency certification

### 2.13.1 Safety certification

The drives are recognized in accordance with UL 1950 and CSA C22.2 (950) and meet all applicable sections of IEC950 and EN 60950 as tested by TUV North America.

### 2.13.2 Electromagnetic compatibility

Hard drives that display the CE mark comply with the European Union (EU) requirements specified in the Electromagnetic Compatibility Directive (89/336/EEC). Testing is performed to the levels specified by the product standards for Information Technology Equipment (ITE). Emission levels are defined by EN 55022, Class B and the immunity levels are defined by EN 55024.

Seagate uses an independent laboratory to confirm compliance with the EC directives specified in the previous paragraph. Drives are tested in representative end-user systems. Although CE-marked Seagate drives comply with the directives when used in the test systems, we cannot guarantee that all systems will comply with the directives. The drive is designed for operation inside a properly designed enclosure, with properly shielded I/O cable (if necessary) and terminators on all unused I/O ports. Computer manufacturers and system integrators should confirm EMC compliance and provide CE marking for their products.

## Korean RRL

If these drives have the Korea Ministry of Information and Communication (MIC) logo, they comply with paragraph 1 of Article 11 of the Electromagnetic Compatibility control Regulation and meet the Electromagnetic Compatibility (EMC) Framework requirements of the Radio Research Laboratory (RRL) Ministry of Information and Communication Republic of Korea.

These drives have been tested and comply with the Electromagnetic Interference/Electromagnetic Susceptibility (EMI/EMS) for Class B products. Drives are tested in a representative, end-user system by a Korean-recognized lab.

- Constellation Serial ATA
- Certificate number: STX- ST9500530NS (B)

## Australian C-Tick (N176)

If these models have the C-Tick marking, they comply with the Australia/New Zealand Standard AS/NZS3548 1995 and meet the Electromagnetic Compatibility (EMC) Framework requirements of the Australian Communication Authority (ACA).

### 2.13.3 FCC verification

These drives are intended to be contained solely within a personal computer or similar enclosure (not attached as an external device). As such, each drive is considered to be a subassembly even when it is individually marketed to the customer. As a subassembly, no Federal Communications Commission verification or certification of the device is required.

Seagate Technology LLC has tested this device in enclosures as described above to ensure that the total assembly (enclosure, disc drive, motherboard, power supply, etc.) does comply with the limits for a Class B computing device, pursuant to Subpart J, Part 15 of the FCC rules. Operation with noncertified assemblies is likely to result in interference to radio and television reception.

**Radio and television interference.** This equipment generates and uses radio frequency energy and if not installed and used in strict accordance with the manufacturer's instructions, may cause interference to radio and television reception.

This equipment is designed to provide reasonable protection against such interference in a residential installation. However, there is no guarantee that interference will not occur in a particular installation. If this equipment does cause interference to radio or television, which can be determined by turning the equipment on and off, you are encouraged to try one or more of the following corrective measures:

- Reorient the receiving antenna.
- Move the device to one side or the other of the radio or TV.
- Move the device farther away from the radio or TV.
- Plug the computer into a different outlet so that the receiver and computer are on different branch outlets.

If necessary, you should consult your dealer or an experienced radio/television technician for additional suggestions. You may find helpful the following booklet prepared by the Federal Communications Commission: *How to Identify and Resolve Radio-Television Interference Problems*. This booklet is available from the Superintendent of Documents, U.S. Government Printing Office, Washington, DC 20402. Refer to publication number 004-000-00345-4.

## 2.14 Environmental protection

Seagate designs its products to meet environmental protection requirements worldwide, including regulations restricting certain chemical substances.

### 2.14.1 European Union Restriction of Hazardous Substances (RoHS) Directive

The European Union Restriction of Hazardous Substances (RoHS) Directive, restricts the presence of chemical substances, including Lead, Cadmium, Mercury, Hexavalent Chromium, PBB and PBDE, in electronic products, effective July 2006. This drive is manufactured with components and materials that comply with the RoHS Directive.

### 2.14.2 China Restriction of Hazardous Substances (RoHS) Directive 中国限制危险物品的指令

This product has an Environmental Protection Use Period (EPUP) of 20 years. The following table contains information mandated by China's "Marking Requirements for Control of Pollution Caused by Electronic Information Products" Standard.



该产品具有20年的环境保护使用周期（EPUP）。下表包含了中国“电子产品所导致的污染的控制的记号要求”所指定的信息。

Name of Parts 部件名称	Toxic or Hazardous Substances or Elements 有毒有害物质或元素					
	Lead 铅 (Pb)	Mercury 汞 (Hg)	Cadmium 镉 (Cd)	Hexavalent Chromium 六价铬 (Cr6+)	Polybrominated Biphenyl 多溴联苯 (PBB)	Polybrominated Diphenyl Ether 多溴二苯醚 (PBDE)
PCBA	X	O	O	O	O	O
HDA	X	O	O	O	O	O

"O" indicates the hazardous and toxic substance content of the part (at the homogenous material level) is lower than the threshold defined by the China RoHS MCV Standard.

"O"表示该部件（于同类物品程度上）所含的危险和有毒物质低于中国RoHS MCV标准所定义的门槛值。

"X" indicates the hazardous and toxic substance content of the part (at the homogenous material level) is over the threshold defined by the China RoHS MCV Standard.

"X"表示该部件（于同类物品程度上）所含的危险和有毒物质超出中国RoHS MCV标准所定义的门槛值。

## 2.15 Corrosive environment

Seagate electronic drive components pass accelerated corrosion testing equivalent to 10 years exposure to light industrial environments containing sulfurous gases, chlorine and nitric oxide, classes G and H per ASTM B845. However, this accelerated testing cannot duplicate every potential application environment. Users should use caution exposing any electronic components to uncontrolled chemical pollutants and corrosive chemicals as electronic drive component reliability can be affected by the installation environment. The silver, copper, nickel and gold films used in Seagate products are especially sensitive to the presence of sulfide, chloride, and nitrate contaminants. Sulfur is found to be the most damaging. In addition, electronic components should never be exposed to condensing water on the surface of the printed circuit board assembly (PCBA) or exposed to an ambient relative humidity greater than 95%. Materials used in cabinet fabrication, such as vulcanized rubber, that can outgas corrosive compounds should be minimized or eliminated. The useful life of any electronic equipment may be extended by replacing materials near circuitry with sulfide-free alternatives.

## 3.0 Configuring and mounting the drive

---

This section contains the specifications and instructions for configuring and mounting the drive.

### 3.1 Handling and static-discharge precautions

After unpacking, and before installation, the drive may be exposed to potential handling and electrostatic discharge (ESD) hazards. Observe the following standard handling and static-discharge precautions:

**Caution:**

- Before handling the drive, put on a grounded wrist strap, or ground yourself frequently by touching the metal chassis of a computer that is plugged into a grounded outlet. Wear a grounded wrist strap throughout the entire installation procedure.
- Handle the drive by its edges or frame *only*.
- The drive is extremely fragile—handle it with care. Do not press down on the drive top cover.
- Always rest the drive on a padded, antistatic surface until you mount it in the computer.
- Do not touch the connector pins or the printed circuit board.
- Do not remove the factory-installed labels from the drive or cover them with additional labels. Removal voids the warranty. Some factory-installed labels contain information needed to service the drive. Other labels are used to seal out dirt and contamination.

### 3.2 Configuring the drive

Each drive on the Serial ATA interface connects point-to-point with the Serial ATA host adapter. There is no master/slave relationship because each drive is considered a master in a point-to-point relationship. If two drives are attached on one Serial ATA host adapter, the host operating system views the two devices as if they were both “masters” on two separate ports. Both drives behave as if they are Device 0 (master) devices.

Serial ATA drives are designed for easy installation. It is usually not necessary to set any jumpers on the drive for proper operation; however, if you connect the drive and receive a “drive not detected” error, your SATA-equipped motherboard or host adapter may use a chipset that does not support SATA speed autonegotiation. If you have a motherboard or host adapter that does not support autonegotiation:

- Install a jumper as shown in Figure 3 below to limit the data transfer rate to 1.5 Gbits per second (and leave the drive connected to the SATA-equipped motherboard or host adapter that doesn't support autonegotiation) or
- Install a SATA host adapter that supports autonegotiation, leave the drive jumper block set to “Normal operation” (see Figure 3 below), and connect the drive to that adapter. This option has the benefit of not limiting the drive to a 1.5 Gbits/sec transfer rate.

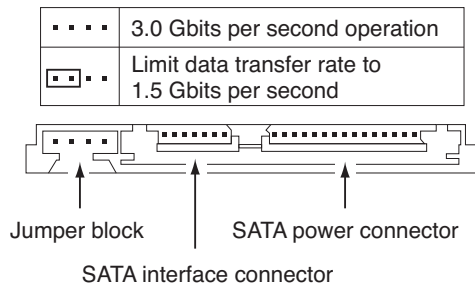

Figure 3. Serial ATA connectors

### 3.3 Serial ATA cables and connectors

The Serial ATA interface cable consists of four conductors in two differential pairs, plus three ground connections. The cable size may be 30 to 26 AWG with a maximum length of one meter (39.37 inches). See Table 5 for connector pin definitions. Either end of the SATA signal cable can be attached to the drive or host.

For direct backplane connection, the drive connectors are inserted directly into the host receptacle. The drive and the host receptacle incorporate features that enable the direct connection to be hot pluggable and blind mateable.

For installations which require cables, you can connect the drive as illustrated in Figure 4.

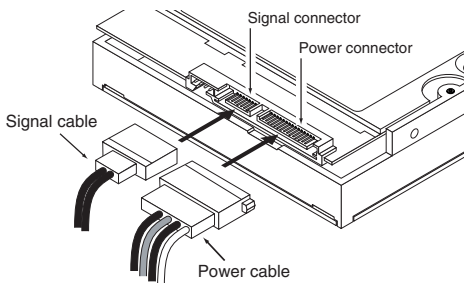

Figure 4. Attaching SATA cabling

Each cable is keyed to ensure correct orientation. Constellation Serial ATA drives support latching SATA connectors.

### 3.4 Drive mounting

You can mount the drive in any orientation using four screws in the side-mounting holes or four screws in the bottom-mounting holes. See Figure 5 for drive mounting dimensions. Follow these important mounting precautions when mounting the drive:

- Allow a minimum clearance of 0.030 inches (0.76 mm) around the entire perimeter of the drive for cooling as a guideline. Please refer to Section 3.5 for final cooling requirements.
- Use only M3 x 0.5 metric mounting screws.
- Four (4) threads (0.080 inches) minimum screw engagement recommended. Also ensure maximum screw length does not bottom out in mounting holes.
- Do not overtighten the mounting screws (maximum torque: 4.5 inch-lb,  $\pm 0.45$  in-lb).

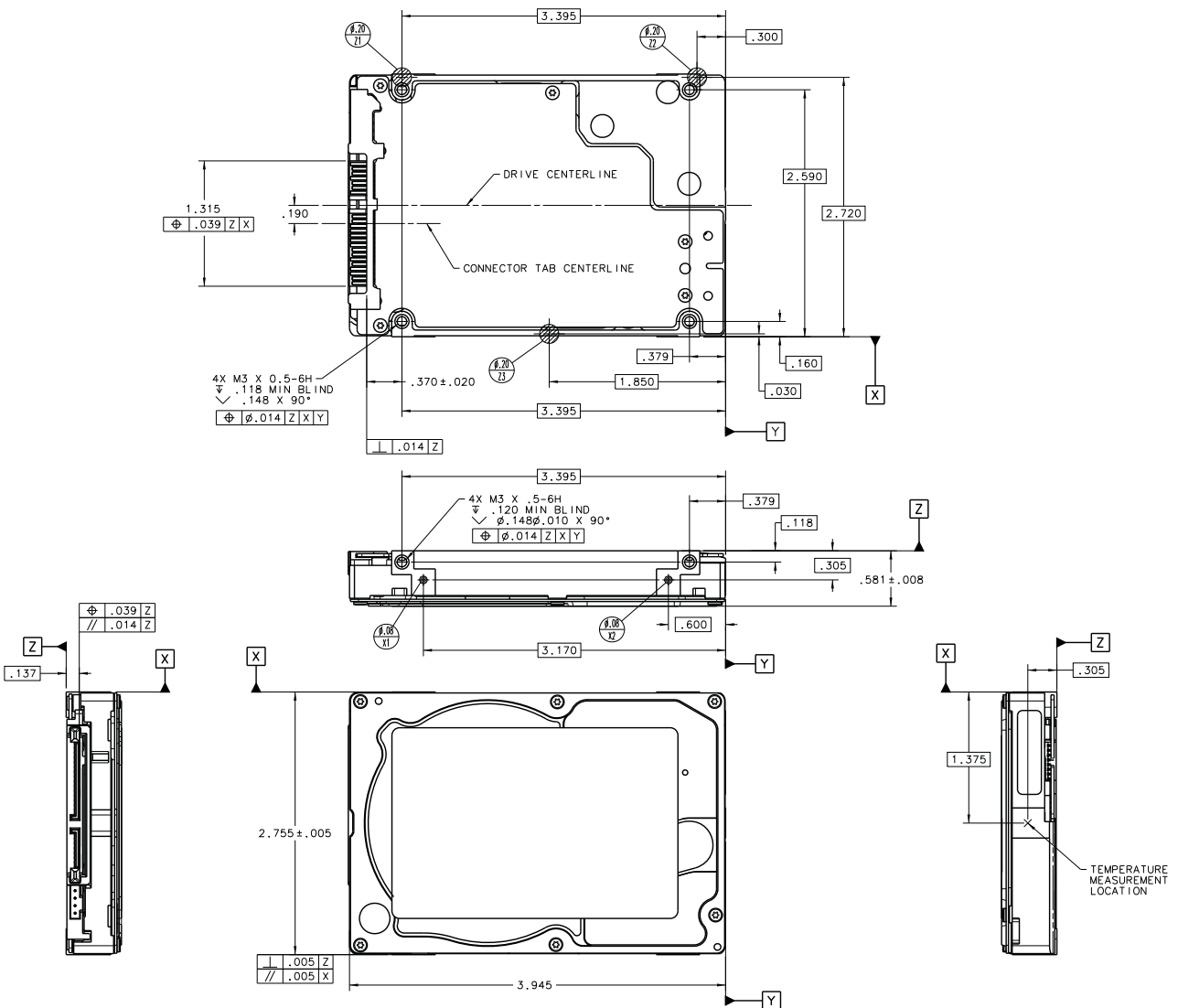

Figure 5. Mounting dimensions—top, side and end view

### 3.5 Cooling

Cabinet cooling must be designed by the customer so that the ambient temperature immediately surrounding the drive will not exceed temperature conditions specified in Section 2.9.1, "Ambient temperature."

The rack, cabinet, or drawer environment for the drive must provide heat removal from the electronics and head and disc assembly (HDA). You should confirm that adequate heat removal is provided using the temperature measurement guidelines described in Section 2.9.1.

Forced air flow may be required to keep temperatures at or below the temperatures specified in Section 2.9.1 in which case the drive should be oriented, or air flow directed, so that the least amount of air flow resistance is created while providing air flow to the electronics and HDA. Also, the shortest possible path between the air inlet and exit should be chosen to minimize the travel length of air heated by the drive and other heat sources within the rack, cabinet, or drawer environment.

If forced air is determined to be necessary, possible air-flow patterns are shown in Figure 6. The air-flow patterns are created by one or more fans, either forcing or drawing air as shown in the illustrations. Conduction, convection, or other forced air-flow patterns are acceptable as long as the temperature measurement guidelines of Section 2.9.1 are met.

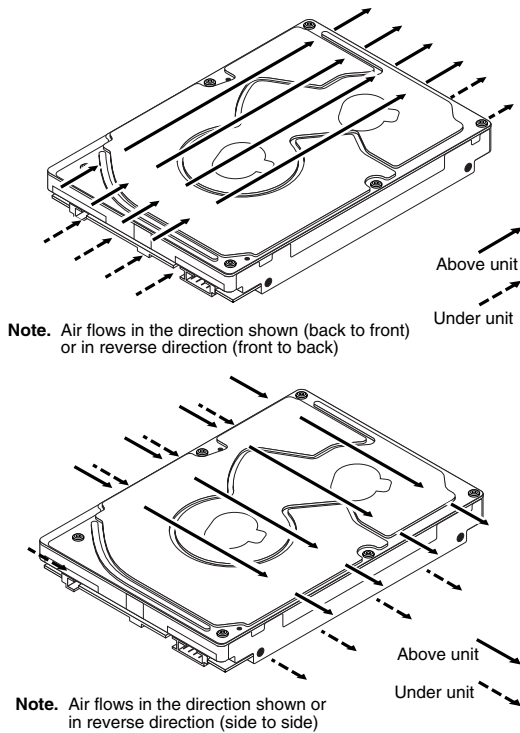

**Figure 6. Air flow**

## 4.0 Serial ATA (SATA) interface

---

These drives use the industry-standard Serial ATA interface that supports FIS data transfers. It supports ATA programmed input/output (PIO) modes 0–4; multiword DMA modes 0–2, and Ultra DMA modes 0–6.

For detailed information about the Serial ATA interface, refer to the “Serial ATA: High Speed Serialized AT Attachment” specification.

### 4.1 Hot-Plug compatibility

Constellation Serial ATA drives incorporate connectors which enable you to hot plug these drives in accordance with the Serial ATA II: Extension to Serial ATA 1.0a specification. This specification can be downloaded from [www.serialata.org](http://www.serialata.org).

#### Caution:

The drive motor must come to a complete stop (**Ready to spindle stop time indicated in Section 2.7**) prior to changing the plane of operation. This time is required to insure data integrity.

## 4.2 Serial ATA device plug connector pin definitions

Table 5 summarizes the signals on the Serial ATA interface and power connectors.

**Table 5: Serial ATA connector pin definitions**

Segment	Pin	Function	Definition
<b>Signal</b>	S1	Ground	2nd mate
	S2	A+	Differential signal pair A from Phy
	S3	A-	
	S4	Ground	2nd mate
	S5	B-	Differential signal pair B from Phy
	S6	B+	
	S7	Ground	2nd mate

Key and spacing separate signal and power segments

<b>Power</b>	P1	V <sub>33</sub>	3.3V power
	P2	V <sub>33</sub>	3.3V power
	P3	V <sub>33</sub>	3.3V power, pre-charge, 2nd mate
	P4	Ground	1st mate
	P5	Ground	2nd mate
	P6	Ground	2nd mate
	P7	V <sub>5</sub>	5V power, pre-charge, 2nd mate
	P8	V <sub>5</sub>	5V power
	P9	V <sub>5</sub>	5V power
	P10	Ground	2nd mate
	P11	Ground or LED signal	If grounded, drive does not use deferred spin
	P12	Ground	1st mate.
	P13	V <sub>12</sub>	12V power, pre-charge, 2nd mate
	P14	V <sub>12</sub>	12V power
	P15	V <sub>12</sub>	12V power

### Notes:

- All pins are in a single row, with a 1.27 mm (0.050") pitch.
- The comments on the mating sequence apply to the case of backplane blindmate connector only. In this case, the mating sequences are:
  - the ground pins P4 and P12.
  - the pre-charge power pins and the other ground pins.
  - the signal pins and the rest of the power pins.
- There are three power pins for each voltage. One pin from each voltage is used for pre-charge when installed in a blind-mate backplane configuration.
- All used voltage pins (V<sub>x</sub>) must be terminated.

### 4.3 Supported ATA commands

The following table lists Serial ATA standard commands that the drive supports. For a detailed description of the ATA commands, refer to the Serial ATA: High Speed Serialized AT Attachment specification. See “S.M.A.R.T. commands” on page 32 for details and subcommands used in the S.M.A.R.T. implementation.

**Table 6: Supported ATA commands**

Command name	Command code (in hex)
Check Power Mode	E5 <sub>H</sub>
Device Configuration Freeze Lock	B1 <sub>H</sub> / C1 <sub>H</sub>
Device Configuration Identify	B1 <sub>H</sub> / C2 <sub>H</sub>
Device Configuration Restore	B1 <sub>H</sub> / C0 <sub>H</sub>
Device Configuration Set	B1 <sub>H</sub> / C3 <sub>H</sub>
Device Reset	08 <sub>H</sub>
Download Microcode	92 <sub>H</sub>
Execute Device Diagnostics	90 <sub>H</sub>
Flush Cache	E7 <sub>H</sub>
Flush Cache Extended	EA <sub>H</sub>
Format Track	50 <sub>H</sub>
Identify Device	EC <sub>H</sub>
Idle	E3 <sub>H</sub>
Idle Immediate	E1 <sub>H</sub>
Initialize Device Parameters	91 <sub>H</sub>
Read Buffer	E4 <sub>H</sub>
Read DMA	C8 <sub>H</sub>
Read DMA Extended	25 <sub>H</sub>
Read DMA Without Retries	C9 <sub>H</sub>
Read Log Ext	2F <sub>H</sub>
Read Multiple	C4 <sub>H</sub>
Read Multiple Extended	29 <sub>H</sub>
Read Native Max Address	F8 <sub>H</sub>
Read Native Max Address Extended	27 <sub>H</sub>
Read Sectors	20 <sub>H</sub>
Read Sectors Extended	24 <sub>H</sub>
Read Sectors Without Retries	21 <sub>H</sub>
Read Verify Sectors	40 <sub>H</sub>
Read Verify Sectors Extended	42 <sub>H</sub>
Read Verify Sectors Without Retries	41 <sub>H</sub>
Recalibrate	10 <sub>H</sub>
Security Disable Password	F6 <sub>H</sub>
Security Erase Prepare	F3 <sub>H</sub>

Command name	Command code (in hex)
Security Erase Unit	F4 <sub>H</sub>
Security Freeze	F5 <sub>H</sub>
Security Set Password	F1 <sub>H</sub>
Security Unlock	F2 <sub>H</sub>
Seek	70 <sub>H</sub>
Set Features	EF <sub>H</sub>
Set Max Address Note: Individual Set Max Address commands are identified by the value placed in the Set Max Features register as defined to the right.	F9 <sub>H</sub> Address: 00 <sub>H</sub> Password: 01 <sub>H</sub> Lock: 02 <sub>H</sub> Unlock: 03 <sub>H</sub> Freeze Lock: 04 <sub>H</sub>
Set Max Address Extended	37 <sub>H</sub>
Set Multiple Mode	C6 <sub>H</sub>
Sleep	E6 <sub>H</sub>
S.M.A.R.T. Disable Operations	B0 <sub>H</sub> / D9 <sub>H</sub>
S.M.A.R.T. Enable/Disable Autosave	B0 <sub>H</sub> / D2 <sub>H</sub>
S.M.A.R.T. Enable Operations	B0 <sub>H</sub> / D8 <sub>H</sub>
S.M.A.R.T. Execute Offline	B0 <sub>H</sub> / D4 <sub>H</sub>
S.M.A.R.T. Read Attribute Thresholds	B0 <sub>H</sub> / D1 <sub>H</sub>
S.M.A.R.T. Read Data	B0 <sub>H</sub> / D0 <sub>H</sub>
S.M.A.R.T. Read Log Sector	B0 <sub>H</sub> / D5 <sub>H</sub>
S.M.A.R.T. Return Status	B0 <sub>H</sub> / DA <sub>H</sub>
S.M.A.R.T. Save Attribute Values	B0 <sub>H</sub> / D3 <sub>H</sub>
S.M.A.R.T. Write Log Sector	B0 <sub>H</sub> / D6 <sub>H</sub>
Standby	E2 <sub>H</sub>
Standby Immediate	E0 <sub>H</sub>
Write Buffer	E8 <sub>H</sub>
Write DMA	CA <sub>H</sub>
Write DMA Extended	35 <sub>H</sub>
Write DMA FUA Extended	CD <sub>H</sub>
Write DMA Without Retries	CB <sub>H</sub>
Write Log Extended	3F <sub>H</sub>
Write Multiple	C5 <sub>H</sub>
Write Multiple Extended	39 <sub>H</sub>
Write Multiple FUA Extended	CE <sub>H</sub>
Write Sectors	30 <sub>H</sub>
Write Sectors Without Retries	31 <sub>H</sub>
Write Sectors Extended	34 <sub>H</sub>

### 4.3.1 Identify Device command

The Identify Device command (command code EC<sub>H</sub>) transfers information about the drive to the host following power up. The data is organized as a single 512-byte block of data, whose contents are shown in Table 6 on page 25. All reserved bits or words should be set to zero. Parameters listed with an “x” are drive-specific or vary with the state of the drive. See Section 2.0 on page 3 for default parameter settings.

The following commands contain drive-specific features that may not be included in the Serial ATA specification.

Word	Description	Value
0	Configuration information: <ul style="list-style-type: none"> <li>• Bit 15: 0 = ATA; 1 = ATAPI</li> <li>• Bit 7: removable media</li> <li>• Bit 6: removable controller</li> <li>• Bit 0: reserved</li> </ul>	0C5A <sub>H</sub>
1	Number of logical cylinders	16,383
2	ATA-reserved	0000 <sub>H</sub>
3	Number of logical heads	16
4	Retired	0000 <sub>H</sub>
5	Retired	0000 <sub>H</sub>
6	Number of logical sectors per logical track: 63	003F <sub>H</sub>
7–9	Retired	0000 <sub>H</sub>
10–19	Serial number: (20 ASCII characters, 0000 <sub>H</sub> = none)	ASCII
20	Retired	0000 <sub>H</sub>
21	Retired	0400 <sub>H</sub>
22	Obsolete	0000 <sub>H</sub>
23–26	Firmware revision (8 ASCII character string, padded with blanks to end of string)	x.xx
27–46	Drive model number: (40 ASCII characters, padded with blanks to end of string)	
47	(Bits 7–0) Maximum sectors per interrupt on Read multiple and Write multiple (16)	8010 <sub>H</sub>
48	Reserved	0000 <sub>H</sub>
49	Standard Standby timer, IORDY supported and may be disabled	2F00 <sub>H</sub>
50	ATA-reserved	0000 <sub>H</sub>
51	PIO data-transfer cycle timing mode	0200 <sub>H</sub>
52	Retired	0200 <sub>H</sub>
53	Words 54–58, 64–70 and 88 are valid	0007 <sub>H</sub>
54	Number of current logical cylinders	xxxx <sub>H</sub>
55	Number of current logical heads	xxxx <sub>H</sub>
56	Number of current logical sectors per logical track	xxxx <sub>H</sub>
57–58	Current capacity in sectors	xxxx <sub>H</sub>
59	Number of sectors transferred during a Read Multiple or Write Multiple command	xxxx <sub>H</sub>

Word	Description	Value
60–61	Total number of user-addressable LBA sectors available (see Section 2.2 for related information) *Note: The maximum value allowed in this field is: 0FFFFFFFh (268,435,455 sectors, 137 Gbytes). Drives with capacities over 137 Gbytes will have 0FFFFFFFh in this field and the actual number of user-addressable LBAs specified in words 100-103. This is required for drives that support the 48-bit addressing feature.	0FFFFFFFh*
62	Retired	0000 <sub>H</sub>
63	Multiword DMA active and modes supported (see note following this table)	xx07 <sub>H</sub>
64	Advanced PIO modes supported (modes 3 and 4 supported)	0003 <sub>H</sub>
65	Minimum multiword DMA transfer cycle time per word (120 nsec)	0078 <sub>H</sub>
66	Recommended multiword DMA transfer cycle time per word (120 nsec)	0078 <sub>H</sub>
67	Minimum PIO cycle time without IORDY flow control (240 nsec)	00F0 <sub>H</sub>
68	Minimum PIO cycle time with IORDY flow control (120 nsec)	0078 <sub>H</sub>
69–74	ATA-reserved	0000 <sub>H</sub>
75	Queue depth	0000 <sub>H</sub>
76	Serial ATA capabilities	xxxx <sub>H</sub>
77	Reserved for future Serial ATA definition	xxxx <sub>H</sub>
78	Serial ATA features supported	xxxx <sub>H</sub>
79	Serial ATA features enabled	xxxx <sub>H</sub>
80	Major version number	003E <sub>H</sub>
81	Minor version number	0000 <sub>H</sub>
82	Command sets supported	364B <sub>H</sub>
83	Command sets supported	7C03 <sub>H</sub>
84	Command sets support extension (see note following this table)	4003 <sub>H</sub> See Word 108-111 note. (4003H = 0100000000000011 binary)
85	Command sets enabled	30xx <sub>H</sub>
86	Command sets enabled	0001 <sub>H</sub>
87	Command sets enable extension	4000 <sub>H</sub>
88	Ultra DMA support and current mode (see note following this table)	xx3F <sub>H</sub>
89	Security erase time	0000 <sub>H</sub>
90	Enhanced security erase time	0000 <sub>H</sub>
92	Master password revision code	FFFE <sub>H</sub>
93	Hardware reset value	xxxx <sub>H</sub>
95–99	ATA-reserved	0000 <sub>H</sub>
100–103	Total number of user-addressable LBA sectors available (see Section 2.2 for related information). These words are required for drives that support the 48-bit addressing feature. Maximum value: 0000FFFFFFFFFh.	500 GB models = 976,773,168 160 GB models = 312,581,808
104–107	ATA-reserved	0000 <sub>H</sub>

Word	Description	Value
108–111	The mandatory value of the world wide name (WWN) for the drive. NOTE: This field is valid if word 84, bit 8 is set to 1 indicating 64-bit WWN support.	Each drive will have a unique value.
112–127	ATA-reserved	0000 <sub>H</sub>
128	Security status	0001 <sub>H</sub>
129–159	Seagate-reserved	xxxx <sub>H</sub>
160–254	ATA-reserved	0000 <sub>H</sub>
255	Integrity word	xxA5 <sub>H</sub>

**Note.** See the bit descriptions below for words 63, 84, and 88 of the Identify Drive data.

Description (if bit is set to 1)	
Bit	Word 63
0	Multiword DMA mode 0 is supported.
1	Multiword DMA mode 1 is supported.
2	Multiword DMA mode 2 is supported.
8	Multiword DMA mode 0 is currently active.
9	Multiword DMA mode 1 is currently active.
10	Multiword DMA mode 2 is currently active.
Bit	Word 84
0	SMART error loggin is supported.
1	SMART self-test is supported.
2	Media serial number is supported.
3	Media Card Pass Through Command feature set is supported.
4	Streaming feature set is supported.
5	GPL feature set is supported.
6	WRITE DMA FUA EXT and WRITE MULTIPLE FUA EXT commands are supported.
7	WRITE DMA QUEUED FUA EXT command is supported.
8	64-bit World Wide Name is supported.
9-10	Obsolete.
11-12	Reserved for TLC.
13	IDLE IMMEDIATE command with IUNLOAD faeture is supported.
14	Shall be set to 1.
15	Shall be cleared to 0.

	<b>Bit</b>	<b>Word 88</b>
	0	Ultra DMA mode 0 is supported.
	1	Ultra DMA mode 1 is supported.
	2	Ultra DMA mode 2 is supported.
	3	Ultra DMA mode 3 is supported.
	4	Ultra DMA mode 4 is supported.
	5	Ultra DMA mode 5 is supported.
	6	Ultra DMA mode 6 is supported.
	8	Ultra DMA mode 0 is currently active.
	9	Ultra DMA mode 1 is currently active.
	10	Ultra DMA mode 2 is currently active.
	11	Ultra DMA mode 3 is currently active.
	12	Ultra DMA mode 4 is currently active.
	13	Ultra DMA mode 5 is currently active.
	14	Ultra DMA mode 6 is currently active.

### 4.3.2 Set Features command

This command controls the implementation of various features that the drive supports. When the drive receives this command, it sets BSY, checks the contents of the Features register, clears BSY and generates an interrupt. If the value in the register does not represent a feature that the drive supports, the command is aborted. Power-on default has the read look-ahead and write caching features enabled. The acceptable values for the Features register are defined as follows:

**Table 7: Set Features command values**

02 <sub>H</sub>	Enable write cache ( <i>default</i> ).
03 <sub>H</sub>	Set transfer mode (based on value in Sector Count register). Sector Count register values:
00 <sub>H</sub>	Set PIO mode to default (PIO mode 2).
01 <sub>H</sub>	Set PIO mode to default and disable IORDY (PIO mode 2).
08 <sub>H</sub>	PIO mode 0
09 <sub>H</sub>	PIO mode 1
0A <sub>H</sub>	PIO mode 2
0B <sub>H</sub>	PIO mode 3
0C <sub>H</sub>	PIO mode 4 ( <i>default</i> )
20 <sub>H</sub>	Multiword DMA mode 0
21 <sub>H</sub>	Multiword DMA mode 1
22 <sub>H</sub>	Multiword DMA mode 2
40 <sub>H</sub>	Ultra DMA mode 0
41 <sub>H</sub>	Ultra DMA mode 1
42 <sub>H</sub>	Ultra DMA mode 2
43 <sub>H</sub>	Ultra DMA mode 3
44 <sub>H</sub>	Ultra DMA mode 4
45 <sub>H</sub>	Ultra DMA mode 5
46 <sub>H</sub>	Ultra DMA mode 6
10 <sub>H</sub>	Enable use of SATA features
55 <sub>H</sub>	Disable read look-ahead (read cache) feature.
82 <sub>H</sub>	Disable write cache
90 <sub>H</sub>	Disable use of SATA features
AA <sub>H</sub>	Enable read look-ahead (read cache) feature ( <i>default</i> ).
F1 <sub>H</sub>	Report full capacity available

**Note.** At power-on, or after a hardware or software reset, the default values of the features are as indicated above.

### 4.3.3 S.M.A.R.T. commands

S.M.A.R.T. provides near-term failure prediction for disc drives. When S.M.A.R.T. is enabled, the drive monitors predetermined drive attributes that are susceptible to degradation over time. If self-monitoring determines that a failure is likely, S.M.A.R.T. makes a status report available to the host. Not all failures are predictable. S.M.A.R.T. predictability is limited to the attributes the drive can monitor. For more information on S.M.A.R.T. commands and implementation, see the *Draft ATA-5 Standard*.

SeaTools diagnostic software activates a built-in drive self-test (DST S.M.A.R.T. command for D4<sub>H</sub>) that eliminates unnecessary drive returns. The diagnostic software ships with all new drives and is also available at: <http://seatools.seagate.com>.

This drive is shipped with S.M.A.R.T. features disabled. You must have a recent BIOS or software package that supports S.M.A.R.T. to enable this feature. The table below shows the S.M.A.R.T. command codes that the drive uses.

**Table 8: S.M.A.R.T. commands**

Code in features register	S.M.A.R.T. command
D0 <sub>H</sub>	S.M.A.R.T. Read Data
D2 <sub>H</sub>	S.M.A.R.T. Enable/Disable Attribute Autosave
D3 <sub>H</sub>	S.M.A.R.T. Save Attribute Values
D4 <sub>H</sub>	S.M.A.R.T. Execute Off-line Immediate (runs DST)
D5 <sub>H</sub>	S.M.A.R.T. Read Log Sector
D6 <sub>H</sub>	S.M.A.R.T. Write Log Sector
D8 <sub>H</sub>	S.M.A.R.T. Enable Operations
D9 <sub>H</sub>	S.M.A.R.T. Disable Operations
DA <sub>H</sub>	S.M.A.R.T. Return Status

**Note.** If an appropriate code is not written to the Features Register, the command is aborted and 0x04 (abort) is written to the Error register.

## 5.0 Seagate Technology support services

---

### Online services

#### Internet

For information regarding Seagate products and services, visit [www.seagate.com](http://www.seagate.com).

Worldwide support is available 24 hours daily by email for your questions.

#### Presales Support:

[Presales@Seagate.com](mailto:Presales@Seagate.com)

#### Technical Support:

[DiscSupport@Seagate.com](mailto:DiscSupport@Seagate.com)

#### Warranty Support:

[http://www.seagate.com/www/en-us/support/warranty & returns assistance](http://www.seagate.com/www/en-us/support/warranty_&_returns_assistance)

#### mySeagate

[my.seagate.com](http://my.seagate.com) is the industry's first Web portal designed specifically for OEMs and distributors. It provides self-service access to critical applications, personalized content and the tools that allow our partners to manage their Seagate account functions. Submit pricing requests, orders and returns through a single, password-protected Web interface-anytime, anywhere in the world.

#### spp.seagate.com

[spp.seagate.com](http://spp.seagate.com) supports Seagate resellers with product information, program benefits and sales tools. You may register for customized communications that are not available on the web. These communications contain product launch, EOL, pricing, promotions and other channel-related information. To learn more about the benefits or to register, go to [spp.seagate.com](http://spp.seagate.com), any time, from anywhere in the world.

### Global Customer Support

#### Presales Support

Our Presales Support staff can help you determine which Seagate products are best suited for your specific application or computer system, as well as product availability and compatibility.

#### Technical Support

Seagate technical support is available to assist you online at [support.seagate.com](http://support.seagate.com) or through one of our call centers. Have your system configuration information and your "ST" model/product number available.

## Customer Service Operations

### Warranty Service

Seagate offers worldwide customer support for Seagate products. Seagate distributors, OEMs and other direct customers should contact their Seagate Customer Service Operations (CSO) representative for warranty-related issues. Resellers or end users of drive products should contact their place of purchase or Seagate warranty service for assistance. Have your serial number and model or part number available.

### Data Recovery Services

Seagate offers data recovery services for all formats and all brands of storage media. Our data recovery services labs are currently located throughout the world. . Additional information, including an online request form and data loss prevention resources, is available at <http://services.seagate.com/index.aspx>.

### Authorized Service Centers

Seagate Service Centers are available on a global basis for the return of defective products. See [www.seagate.com](http://www.seagate.com) for the service center near you.

### USA/Canada/Latin America support services

For an extensive list of telephone numbers to technical support, presales and warranty service in USA/Canada/Latin America, including business hours, go to the "Contact Us" page on [www.seagate.com](http://www.seagate.com).

## Global Customer Support

### Presales, Technical, and Warranty Support

Call Center	Toll-free	Direct dial
USA, Canada, and Mexico	1-800-SEAGATE	+1-405-324-4700

### Data Recovery Services

Call Center	Toll-free	Direct dial	FAX
USA, Canada, and Mexico	1-800-475-0143	+1-905-474-2162	1-800-475-0158 +1-905-474-2459

## Europe, the Middle East and Africa Support Services

For an extensive list of telephone numbers to technical support, presales and warranty service in Europe, the Middle East and Africa, go to the "Contact Us" page on [www.seagate.com](http://www.seagate.com).

## Asia/Pacific Support Services

For an extensive list of telephone numbers to technical support, presales and warranty service in Asia/Pacific, go to the "Contact Us" page on [www.seagate.com](http://www.seagate.com).

# Index

## A

ACA 17  
acceleration 14  
acoustics 15  
Agency certification 16  
altitude 13  
Ambient temperature 13  
ambient temperature 7, 8  
Annualized Failure Rate (AFR) 16  
areal density 1, 6  
ATA commands 25  
Australia/New Zealand Standard AS/NZS3548 1995 17  
Australian Communication Authority (ACA) 17  
Australian C-Tick 17  
Average latency 7  
Average seek time 7

## B

BPI 6  
buffer 7

## C

cables and connectors 20  
cache 7  
capacity 6  
case temperature 13  
CE mark 16  
certification 16  
Check Power Mode 25  
China RoHS directive 18  
Class B computing device 17  
compatibility 16  
Conducted noise 11  
Conducted RF immunity 15  
Configuring the drive 19  
connectors 20  
Corrosive environment 18  
CSA C22.2 (950) 16  
cycles 16  
Cylinders 6

## D

data-transfer rates 1  
DC power 8  
Default logical geometry 6  
density 6  
Device Configuration Freeze Lock 25  
Device Configuration Identify 25  
Device Configuration Restore 25

Device Configuration Set 25  
Device Reset 25  
dimensions 21  
Download Microcode 25

## E

Electrical fast transient 15  
Electromagnetic compatibility 16  
Electromagnetic Compatibility (EMC) 17  
Electromagnetic Compatibility control Regulation 17  
Electromagnetic Compatibility Directive (89/336/EEC) 16  
Electromagnetic immunity 15  
Electrostatic discharge 15  
electrostatic discharge (ESD) 19  
EN 55022, Class B 16  
EN 55024 16  
EN 60950 16  
Environmental specifications 13  
error-correction algorithms 1  
errors 16  
ESD 19  
EU 16  
EU RoHS directive 18  
European Union (EU) requirements 16  
Execute Device Diagnostics 25

## F

FCC verification 17  
features 1  
Federal Communications Commission 17  
Flush Cache 25  
Flush Cache Extended 25  
Format Track 25  
Formatted capacity 6

## G

geometry 6  
Gs 14  
guaranteed sectors 6

## H

Handling precautions 19  
heads 6  
height 7  
humidity 13

## I

I/O data-transfer rate 6  
Identify Device 25  
Identify Device command 27  
Idle 25  
Idle Immediate 25

IEC950 16  
Information Technology Equipment (ITE) 16  
Initialize Device Parameters 25  
Input noise ripple 11  
input voltage 8  
interface 6, 23  
internal data-transfer rate OD 6  
is 7  
ISO document 7779 15  
ITE 16

## K

Korea Ministry of Information and Communication  
(MIC) 17  
Korean RRL 17

## L

latency 7  
LBA mode 6  
length 7  
logical geometry 6

## M

maintenance 16  
master/slave 2  
maximum temperature 13  
MIC 17  
mounting 21  
mounting screws 13  
mounting the drive 19

## N

noise 11  
nominal power 7  
Nonoperating shock 13  
Nonoperating vibration 14  
Nonrecoverable read errors 16

## O

Operating shock 13  
Operating vibration 14

## P

Physical characteristics 7  
point-to-point 2, 20  
Power consumption 8  
Power specifications 8  
Power-management modes 12  
Power-on to Ready 7  
precautions 19  
printed circuit board 19

## Q

quick reference 3

## R

Radiated RF immunity 15  
Radio and television interference 17  
radio frequency (RF) 15  
Read Buffer 25  
Read DMA 25  
Read DMA Extended 25  
Read DMA without Retries 25  
read errors 16  
Read Log Ext 25  
Read Multiple 25  
Read Multiple Extended 25  
Read Native Max Address 25  
Read Native Max Address Extended 25  
Read Sectors 25  
Read Sectors Extended 25  
Read Sectors Without Retries 25  
Read Verify Sectors 25  
Read Verify Sectors Extended 25  
Read Verify Sectors Without Retries 25  
Read/write heads 6  
Recalibrate 25  
recording density 6  
recording method 6  
Recording technology 6  
relative humidity 13  
Reliability 16  
RF 15  
RMS read/write current 11  
RoHS 18  
RRL 17

## S

S.M.A.R.T. Disable Operations 26  
S.M.A.R.T. Enable Operations 26  
S.M.A.R.T. Enable/Disable Autosave 26  
S.M.A.R.T. Execute Offline 26  
S.M.A.R.T. implementation 25  
S.M.A.R.T. Read Attribute Thresholds 26  
S.M.A.R.T. Read Data 26  
S.M.A.R.T. Read Log Sector 26  
S.M.A.R.T. Return Status 26  
S.M.A.R.T. Save Attribute Values 26  
S.M.A.R.T. Write Log sector 26  
Safety certification 16  
SATA 23  
screws 13  
sectors 6  
Sectors per track 6  
Security Disable Password 25  
Security Erase Prepare 25

- Security Erase Unit 26
- Security Freeze 26
- Security Set Password 26
- Security Unlock 26
- Seek 26
- Seek time 7
- Serial ATA (SATA) interface 23
- serial ATA ports 2
- Set Features 26
- Set Max Address 26
- Set Max Address Extended 26
- Set Multiple Mode 26
- Shock 13
- single-track seeks 7
- Sleep 26
- sound 15
- Specification summary table 3
- spindle speed 6
- Spinup power 8
- Standby 26
- Standby Immediate 26
- Standby mode 8
- Standby to Ready 7
- Start/stop times 7
- start-stop cycles 16
- static-discharge 19
- support services 33
- Surge immunity 15

- Write DMA Extended 26
- Write DMA FUA Extended 26
- Write DMA Without Retries 26
- Write Log Extended 26
- Write Multiple 26
- Write Multiple Extended 26
- Write Multiple FUA Extended 26
- Write Sectors 26
- Write Sectors Extended 26
- Write Sectors Without Retries 26

## T

- technical support services 33
- temperature 7, 13
- temperature gradient 13
- track density 6
- Track-to-track 7
- Track-to-track seek time 7
- TUV North America 16

## U

- UL 1950 16

## V

- Vibration 14
- voltage 8
- Voltage dips, interrupts 15
- Voltage tolerance 11

## W

- weight 7
- wet bulb temperature 13
- width 7
- Write Buffer 26
- Write DMA 26







**Seagate Technology LLC**  
**920 Disc Drive, Scotts Valley, California 95066-4544, USA**  
*Publication Number: 100538694, Rev. C*